



# Grow Lighting

---

4Twenty Grow Lighting

## 420 LED System

Technical Specification

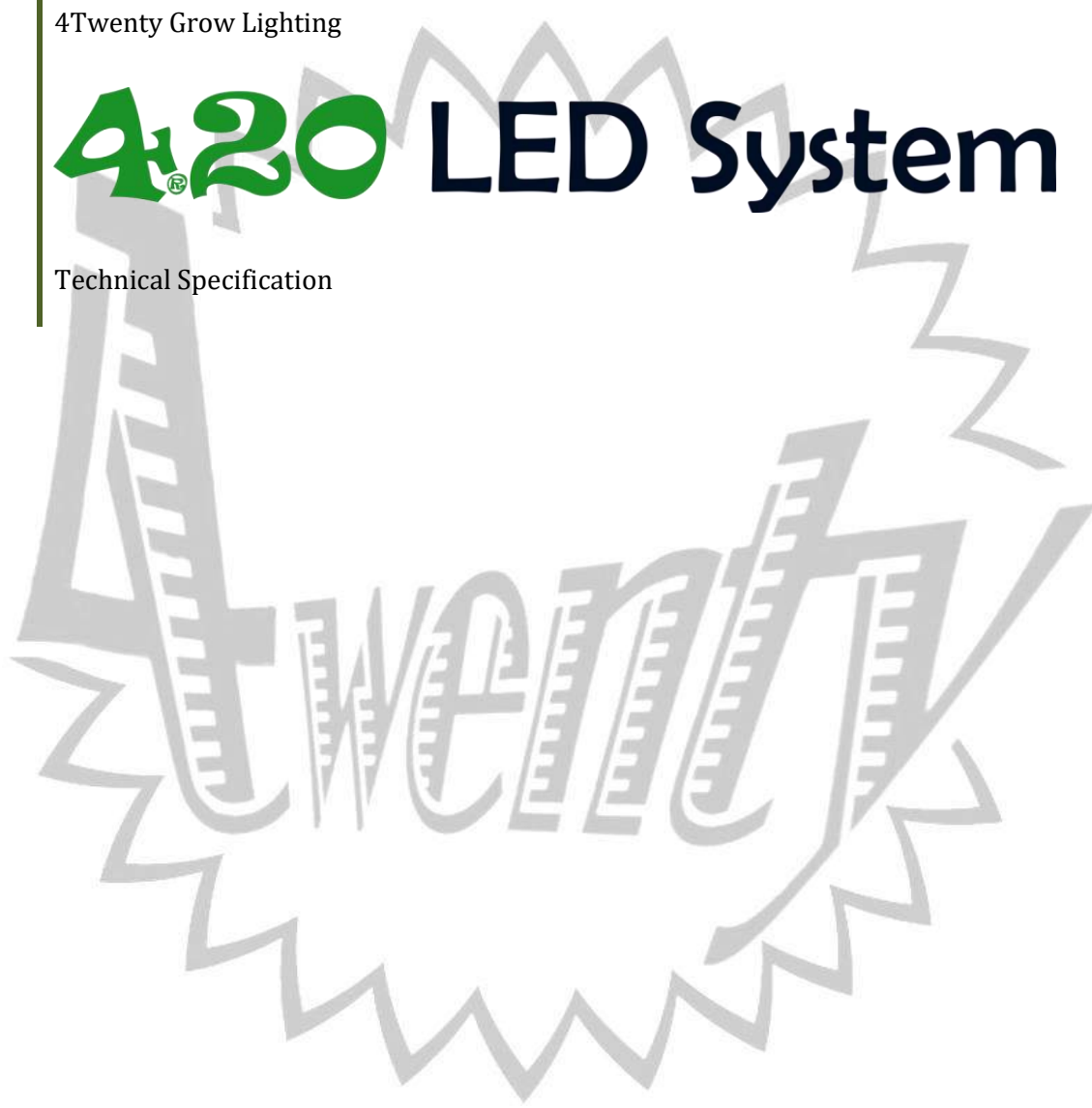

Release Version: V3.0

Release Date: 2023/06/01

## Advantages 420 LED System

### 1. High efficiency and Energy saving

The 420 LED System is equipped with Samsung LM301B LEDs with an efficiency of 2.9  $\mu\text{mol/J}$ . Compared to HPS grow lights, the 420 LED system gives plants more light intensity and better growth rates, but consumes less than 50% of the electricity.

### 2. Long life span

The LEDs used for the 420 LED system are Samsung Horticulture Series LEDs. The LEDs have been specially developed for the horticultural environment, which ensures that the LEDs can withstand extreme temperatures, humidity and exposure to chemicals. This guarantees a high light output, high quality and high reliability with a long service life.

### 3. Dim function

The 420 LED system features a full plant spectrum. With a 10% - 100% dimmer, the light intensity can be adjusted to the needs of plants during all phases of plant growth.

### 4. Waterproof

The 420 LED system has a full IP66 waterproof rating. The LEDs are attached to the aluminum frame and sealed watertight by a high transmission optical lens.

### 5. Plug & Play

No installation required; no reflector and ballast are needed. The 420 LED system is a plug and play grow light. Plug directly into a grounded 110- or 230-volt outlet, making installation simple and safe.

### 6. Modular Connecting System [MCS]

The 420 LED system is modular and can be connected together to form a larger luminaire. With optional aluminum couplers, an endless number of lights can be connected to customize the 420 LED system for any grow space.

### 7. Advanced thermal design

The LEDs are passively cooled for optimal LED performance. If the temperature of the 420 LED System is too high, the light automatically dims to 50%. After cooling, the light returns to full strength. Passive LED cooling is preferable to active ones; due to the lack of moving parts, it is more energy efficient and maintenance-free!

### 8. Environment friendly

A 4Twenty LED System does not contain the harmful substances of HPS & MH lamps. So, there is no hazardous waste, which makes our earth cleaner and greener. LEDs are superior to other lighting technologies in terms of negative environmental and health impacts during the manufacturing process. The production of LEDs requires much less energy than the production of other lighting products and also contains no mercury and little or no toxins such as iodine and lead.

420 LED System



Modular Connecting System [MCS]

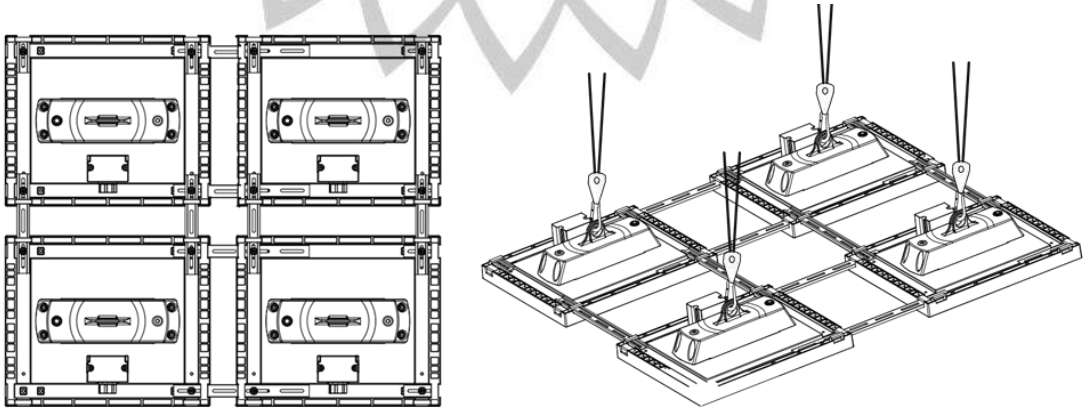
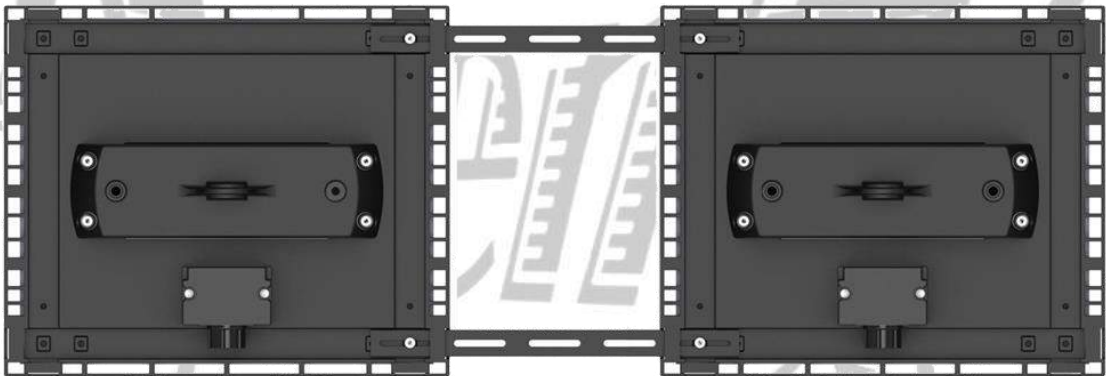

## 420 LED Spectrum

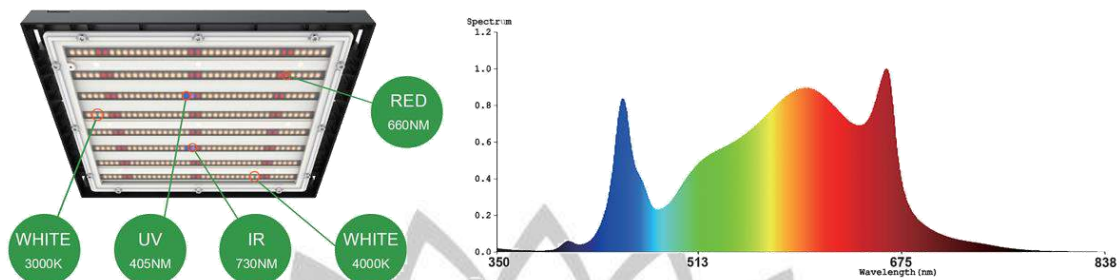

## Technical specification 420LS150

Item	Value	Item	Value
LED chips	Samsung LM301B	Power consumption	Max. 150 Watt
LED amount	312 pieces	Dimmer	10% - 100%
PPF LEDs	2,9 μmol/J	Quality certified	Intertek, DLC 5.2
LED beam angle	120°	Waterproof level	IP66
LED wavelength	~ 330 – 830nm	Voltage	100V – 277V
Height above plants	25 – 50 cm	Work frequency	50Hz / 60Hz
Lifespan	Up to 50.000 hours	Working environment	-20 ~ + 40°C
Lighting area	Infinite [by MCS]	MCS couplers	Optional
Size LED System	300*250*70mm	Net weight	2,8 Kg / pc

## Certification and Warranty of 420 LED System



**Note:**

1. Select a different exposure time depending on the growth stage and plant species.
2. Do not look directly at the LED light without wearing sunglasses.
3. The power socket must be earthed.
4. The 420 LED system is compliant with ELT, FCC, DLC 5.2, CE and RoHs.
5. After sales service; 5-year limited factory warranty, from date of manufacture!